



8-Piece Band Show Rider

On behalf of the cast and crew of Five By Design's *Radio Days*, we wish to thank you for contracting the company as part of your upcoming season. To ensure that the performance runs efficiently, we require your Production/Technical Manager to thoroughly read the enclosed contractual and technical information and sign below. This rider is an integral part of the contract. Please be sure to retain the original document for your records and fax or mail a signed copy to us at:

Five By Design
1160 Vierling Drive, #353
Shakopee, MN 55379-4313
Fax # (952) 400-4229

We understand each venue may have certain limitations. Please feel free to contact us to discuss alternatives or substitutions if you should have any questions regarding the materials contained in this rider. We can be reached through our office at (800) 449-7345.

Warmest regards,

Five By Design

(Production/Technical Manager)

(Telephone Number)

(Date)

Five By Design personnel:

Kurt Niska.....Artistic Director/C.E.O..... (612) 802-8171
Sheridan Zuther.....Operations Manager..... (612) 799-0245
Kellie DeJardin.....Technical Director..... (612) 991-2193
Phil Henrickson.....Sound Engineer.....(920) 755-2328

Artist Representation:

Alton Accola.....*Symphony Pops*..... (800) 449-7345
Lynn Callahan.....*Performing Arts Centers*.....(612) 991-3528

RADIO DAYS 8-PIECE BAND RIDER

These items are necessary to a successful production. Your assistance in providing this information and materials will greatly assist Five By Design to present the best possible performance. Please review them and call us at (800) 449-7345 if you have questions or concerns.

Five By Design personnel:

Kurt Niska..... Artistic Director/C.E.O..... (612) 802-8171
Sheridan Zuther..... Operations Manager..... (612) 799-0245
Kellie DeJardin..... Technical Director..... (612) 991-2193
Phil Henrickson..... Sound Engineer..... (920) 755-2328

IN ADVANCE:

- 1) Professional lighting and sound system to meet specifications of the enclosed "Lighting" and "Sound" requirements. Experienced technicians available to assist with Load-In, Load-Out, and to answer any questions. Please read the attached "Sound" and "Lighting" pages for specific information.
- 2) Business and/or home phone numbers of presenter, venue's technical director and staff.
- 3) A map detailing the location of hotel, performing arts venue, appropriate routing, and phone numbers. Please be specific as to the location of loading dock and the stage door of your venue when providing directions.
- 4) A schematic of the performance venue stage (including an inventory of lighting and sound equipment).
- 5) Hotel or Motel (Residence Inn, Courtyard, Comfort Suites, or comparable) near venue with swimming pool, sauna, whirlpool, exercise facility, and internet access. **NON-SMOKING ROOMS** are required, all at the same complex.
- 6) A hot meal for COMPANY of sixteen (16) during load-in or day of show. For more information, contact Five By Design's Operations Manager.
- 7) Allow broadcast and print media the opportunity to photograph and/or videotape segments of the rehearsal or performance with big band. (No flash photography during performance.)
- 8) Regarding social functions or outreach activities, please inform company a minimum of 30 days in advance.
- 9) If contract states presenter is responsible for providing part or all of the band, please provide name and address of who is to receive the musical scores and parts. Please provide rehearsal availability and schedule as soon as possible to our Operations Manager.
- 10) Piano is to be provided by presenter. If contract states presenter is responsible for providing part or all of the band, an Acoustic Bass (with Pickup and Amplifier) and Drum Kit may need to be provided by presenter. Please see the "Instrumentation List" included for specific information.
- 11) Production specific marketing and promotional materials are available for presenter at company's website: <http://www.fivebydesign.com/RadioDays.html>. Prior to going to print, contact our Operations Manager for program information, content and layout approval (i.e., personnel and program changes). If additional needs or questions arise, please contact our Marketing Director for assistance.

RADIO DAYS 8-PIECE BAND RIDER

PRIOR TO LOAD-IN:

- 1) Piano must be tuned prior to (but within 24 hours of) Load-In, following Rehearsal prior to performance, and before each subsequent performance. If venue has a second (rehearsal) piano, please make it accessible for warm up prior to show and during intermission.
- 2) The Stage Set-Up must be complete prior to Load-In. Lighting instruments should also be pre hung and gelled before Load-In. See attached "Set-Up Diagram" and "Lighting" pages for specific requirements.

AT LOAD-IN:

- 1) Performance venue must be available for Load-In a minimum of eight (8) hours prior to rehearsal with the band. (In the event of an AM rehearsal, venue must be available for Load-In the afternoon prior.) Performance venue must also be available Two (2) hours prior to each performance
 - Load-In typically takes six (6) to seven (7) hours [not including meal breaks].
 - Load-Out typically takes two (2) to two and a half (2-1/2) hours.
- 2) Five (5) Stagehands for Load-In & Load-Out. Four (4) Stagehands for Show Call.
Load-In & Load-Out Crew Requirements: 1 Sound, 1 Light, 1 Wardrobe, 2 Hands.
Show Call Crew Requirements: 1 Sound, 1 Light, 1 Follow spot, 1 Backstage (SR).
- 3) The following are required no later than Load-In time:
 - A 30" - 32" Tam Tam (Gong) with floor stand. (will be used by a cast member)
 - Two (2) sturdy movable clothing racks (preferably high enough to accommodate floor length gowns).
 - One (1) eight foot table for offstage right Quickchange area.
 - One (1) six foot table, stage worthy for Sound Effects area onstage right (see set-up diagram).
 - Fourteen (14) chairs (6 onstage for band, 8 offstage right).
 - Thirteen (13) Music stands (11 onstage, 2 offstage right).
 - Twelve (12) Music Stand Lights (10 onstage, 2 offstage right) **Onstage lights will be on a dimmer.** Company will provide a light for the piano that should be included in the circuit allocated to the stand lights. See attached "Lighting" rider.
 - One (1) 30" stool.
 - Pipe and drape may be needed to create a Quickchange area located off Stage Right 16' x 20'. The location will be determined during Load-In.
 - Three (3) gallons of **distilled** water for our clothing steamers. (**Not** drinking, spring or tap water.)
 - Access to Stage Right from house, i.e. steps.
 - Hot herbal tea (non caffeinated with honey and lemon) regular coffee, non carbonated bottled water (i.e. Evian), Coca-Cola and cups. Please have bottled water, herbal tea and coffee available at rehearsal and performance as well.
 - Fruit and veggie trays available for cast and crew following each performance(s).
 - Four (4) clean Dressing Rooms to accommodate 2 people each, through run of show.
 - One (1) Chorus Dressing Room to accommodate 13 people on day of rehearsal and/or performance.
 - Company travels with a 24' box truck (35' feet long, 13' high) and a 15 passenger van (7' high). **Please arrange for level, secure parking.** The truck is equipped with a battery cutoff switch.

RADIO DAYS 8-PIECE BAND LIGHTING REQUIREMENTS

Questions regarding lighting requirements contact:

Kellie DeJardin, Technical Director:cell: **(612) 991-2193**

e-mail: **technicaldirector@fivebydesign.com**

- Please mail, email, or fax a schematic of your performance venue stage and lighting grid (including a lighting inventory) to company's Operations Manager.

Radio Days requires a safe and well maintained lighting system. The inventory must be adequate to complete the hanging of the enclosed plot prior to Load-In. Please have a safe lift or ladder available for focus. **If you anticipate the need to rent any equipment for your venue, please contact our Technical Director prior to doing so, to make certain it is necessary. Substitutions may be suggested.**

CONSOLE

The lighting console must be either a computer memory console or a two scene preset board with a minimum of 24 channels (ETC or Strand family preferred).

FOLLOW SPOT

We require one (1) follow spot adequate to the venue. A xenon Super Trouper is preferred for medium to large venues. Spot Color is Rosco 02, 33, 54, 60, 119 or 132 (in frames 1 through 5 respectively). LEE or GAM substitutions are acceptable.

CREW REQUIREMENTS

We require one technician familiar with your lighting system to be present at Load-In and during the run of the show, and one follow spot operator for run of the show. Our Technical Director will operate the board for the run of the show. If this presents a problem, please contact our technical personnel at least thirty (30) days in advance of the performance. Five (5) Stagehands are required for Load-In & Load-Out, and to assist with other incidental needs.

- Load-In & Load-Out Crew Requirements: 1 Sound, 1 Light, 1 Wardrobe, 2 Hands.
- Show Call Crew Requirements: 1 Sound, 1 Light, 1 Follow spot, 1 Backstage Right.

BIG BAND REQUIREMENTS

The Big Band Set-Up (see diagram) must be completed prior to the scheduled Load-In. The appropriate background for the production is a full-stage **black curtain** behind the band (hung 35 - 40 feet upstage of the proscenium). **Music stands and stand lights** are required for the musicians. (These stands are included in the count requested on page 3 in the "At Load-In" section.) Five By Design will provide a light for the piano that should be included in the circuit allocated to the stand lights. **Stand Lights for the band will be on a dimmer, patched in to Channel 31.** Please make a dimmer available. Refer to the Set-Up Diagram for additional requirements.

GOBO REQUIREMENTS

Presenter will provide all gobos used for the production:

- Two (2) Rosco gobo pattern #79117-Dense Leaves 3 (Channel 20 on Light Plot).

IMPORTANT INFORMATION REGARDING THE LIGHT PLOT

1. Trim heights are approximately 23 feet.
2. All instruments should be at least 750 watts and should be consistent wattage for equal throw distances.
3. If substitutions of either inventory or color are anticipated, please contact our Technical Director.
4. There are five (5) Practicals **and** five (5) floor mounted Par Cans. Please make dimmers available (see stage requirements and light plot for more information).
5. The light plot is based on a forty (40) foot proscenium. If your performance space is different, please expand or condense the spacing on the electrics as needed.
6. Please refer to light plot for additional notes.

Please Note: In order to ensure a quick and proper load-in of the show, we ask that all lights be gelled and hung prior to Load-In. If this cannot be accommodated, please contact company Technical Director immediately.

RADIO DAYS 8-PIECE BAND SOUND REQUIREMENTS

Questions regarding sound requirements contact:

Phil Henrickson, Sound Engineer: (920) 755-2328.....fax: (920)755-4442
e-mail: philhenrickson@yahoo.com

- Company travels with a system adequate for a 1000 seat auditorium with no balcony. Please advise as to size of venue and type of in-house system available as company may need to patch in to the House PA for additional coverage. **If you anticipate the need to rent any equipment for your venue, please contact our Sound Engineer prior to doing so, to make certain it is necessary.**
- Sound Engineer will use his own console for the purpose of mixing the live performance. Please provide a five (5) foot by eight (8) foot house-mix position for company's sound gear. Rear of house on the main floor is preferred.
- If the cable path from the stage to the House Mix position is greater than one hundred and fifty (150) feet, please provide one (1) Snake, with 24 in - 5 out minimum.
- Three (3) separate twenty (20) amp circuits exclusively for sound gear. One located at House Mix position, one located off stage left, and one for Bass Player's amplifier onstage (see Set-Up Diagram).
- Please provide a Plexiglas surround for the drum kit (three of four sides is fine).
- Seven (7) microphone stands (five (5) straight stands and two (2) boom stands).
- Company travels with Four (4) monitors for the big band. Please provide Two (2) 12" or 15" monitors for company to use as needed.

CREW REQUIREMENTS

We require one technician familiar with your sound system to be present at Load-In and during the run of the show. Five (5) Stagehands are required for Load-In & Load-Out, and to assist with incidental needs.

- Load-In & Load-Out Crew Requirements: 1 Sound, 1 Light, 1 Wardrobe, 2 Hands.
- Show Call Crew Requirements: 1 Sound, 1 Light, 1 Follow spot, 1 Props.

COMMUNICATION

We require two-way headset communication at the following locations:

- lighting console
 - follow spot
 - stage right
 - sound mix
 - stage left (optional)
- **PLEASE CALL 3 - 4 weeks prior** to Load-In to clarify, verify, and address any questions or concerns.

RADIO DAYS 8-PIECE BAND STAGE REQUIREMENTS

Questions regarding stage requirements contact:

Kellie DeJardin, Technical Director:cell: **(612) 991-2193**

e-mail: **technicaldirector@fivebydesign.com**

- The Big Band Set-Up (see diagram) must be completed prior to the scheduled Load-In.
- The appropriate background for the production is a full stage **black curtain** behind the band (hung 35' to 40' upstage of the proscenium).
- We require a minimum of seventeen (17) feet down stage of the piano for performance space. Please contact our Technical Director if this cannot be accommodated.
- We require backstage wing space for Quickchanges: off stage right (approximately 16' x 20') to accommodate two (2) clothes racks, one gondola, one 8'-0" table and eight (8) chairs.
- Theatre borders and legs will be used for masking. If this is not sufficient to properly mask Quickchange area from audience view, pipe and drape may need to be provided. Quickchange area will be determined at Load-In.

BRIEF EXPLANATION OF OUR PROPS

- All scenery elements on the Set-Up Diagram are pieces that we bring with us except the 6'-0" Sound Effects area table and the 30" - 32" Tam Tam (Gong) with stand; these items will be provided by the presenter. This table should be sturdy and nice enough to be seen onstage without the use of skirting.
- We have five (5) scenic pieces that are Edison plug practical units (Including the Radio, the Lamp, the "Applause" sign, the "On-Air" Sign, and the "Shadow" light). These should all be on separate circuits.
- The "On Air" sign is a hanging unit that measures 24" by 8" by 10" and weighs about 3 pounds. We would like to hang this unit up-stage center. If the nature of your venue dictates that the sign cannot be hung, it can be attached to a tripod that will put it six (6) feet off the deck. The sign is a practical unit that will need to have a separate circuit running to it. Line Set will be determined at Load-In.
- During a portion of our show, we recreate sound effects onstage. In this segment, birdseed is used to produce a "rain" effect, and glass is broken into a crash box. Both effects will make a small mess on stage right. Please make sure to have a vacuum cleaner available after each performance.

ITEMS THAT THE PRESENTER NEEDS TO PROVIDE:

- Four (4) skirted risers for the band i.e. Wenger standard 4'-0" by 8'-0" risers at incremental heights of 16" (or optional 8") and 24". **The back of both lower and upper levels must have a chair rail attached.** The Big Band Set-Up (see diagram) must be completed prior to the scheduled Load-In.
- The appropriate background for the production is a full-stage **black curtain** behind the band (hung 35 - 40 feet upstage of the proscenium).
- Thirteen (13) Music stands (11 onstage, 2 offstage right).
- 12 (12) Music Stand Lights (10 onstage, 2 offstage right). Onstage lights will be on a dimmer. Company will provide a light for the piano that should be included in the circuit allocated to the stand lights. **Stand Lights for the band will be on a dimmer, patched in to Channel 31.** Please make a dimmer available. Refer to the Set-Up Diagram for additional requirements.
- One (1) Concert Grand Piano (Piano must be tuned prior to (but within 24 hours of) Load-In, following Rehearsal prior to performance, and before each subsequent performance). **NOTE: In addition, the Acoustic Bass (with Pick-Up & Amplifier) and Drum Kit may need to be provided by presenter. Please see the "contract" for additional information.**
- One (1) eight foot table, offstage right for Quickchange area.
- One (1) six foot table, stage worthy for Sound Effects area onstage right.
- Fourteen (14) chairs (6 onstage, 8 offstage right).
- One (1) 30" stool.
- A 30" - 32" Tam Tam (Gong) with floor stand. (will be used by a cast member)



Five By Design
1160 Vierling Drive, #353
Shakopee, MN 55379-4313
(800) 449-7345

e-mail: **terrence.niska@fivebydesign.com**
Terrence Niska, Music Librarian

INSTRUMENTATION LIST* FOR *RADIO DAYS* 8-PIECE BAND

****This is only a list of the instruments used in our orchestrations. Please check the Contractual Agreement before hiring any players to insure accurate personnel responsibilities are understood.***

- Lead Alto - dbl. flute, piccolo
- Lead Tenor - dbl. clarinet, bari sax (optional)
- Trumpet 1 - dbl. flugelhorn (all mutes)
- Trumpet 2 - dbl. flugelhorn (all mutes)
- Trombone (all mutes)
- Piano (**pianist/conductor provided by "Five By Design"**)
- Bass (upright w/pickup & amp, bow)
 - 3/4-7/8 Size Bass
 - Fully Carved instrument with bow (German, French, Italian)
 - Thomastik Spirocores strings
 - Pickup attached, preferably "The Realist"
 - Bass Amp Recommendations : Yamaha, Mesa Boogie
- Four-piece Drum Set (bass, snare, rack tom, floor tom); Hi-hat stand, Three (3) cymbal stands – at least one with a boom, Bass pedal, Cowbell (and attachment device – "The Claw" or something similar OR another cymbal stand), Throne, and Rug. Snare head should be coated.

RADIO DAYS LIGHT PLOT (8 PIECE)

DESIGNED BY: JAY D. PASKA
REVISED 04-05-10 BY: KN

R.D. PLOT (8) PAGE 1 OF 2

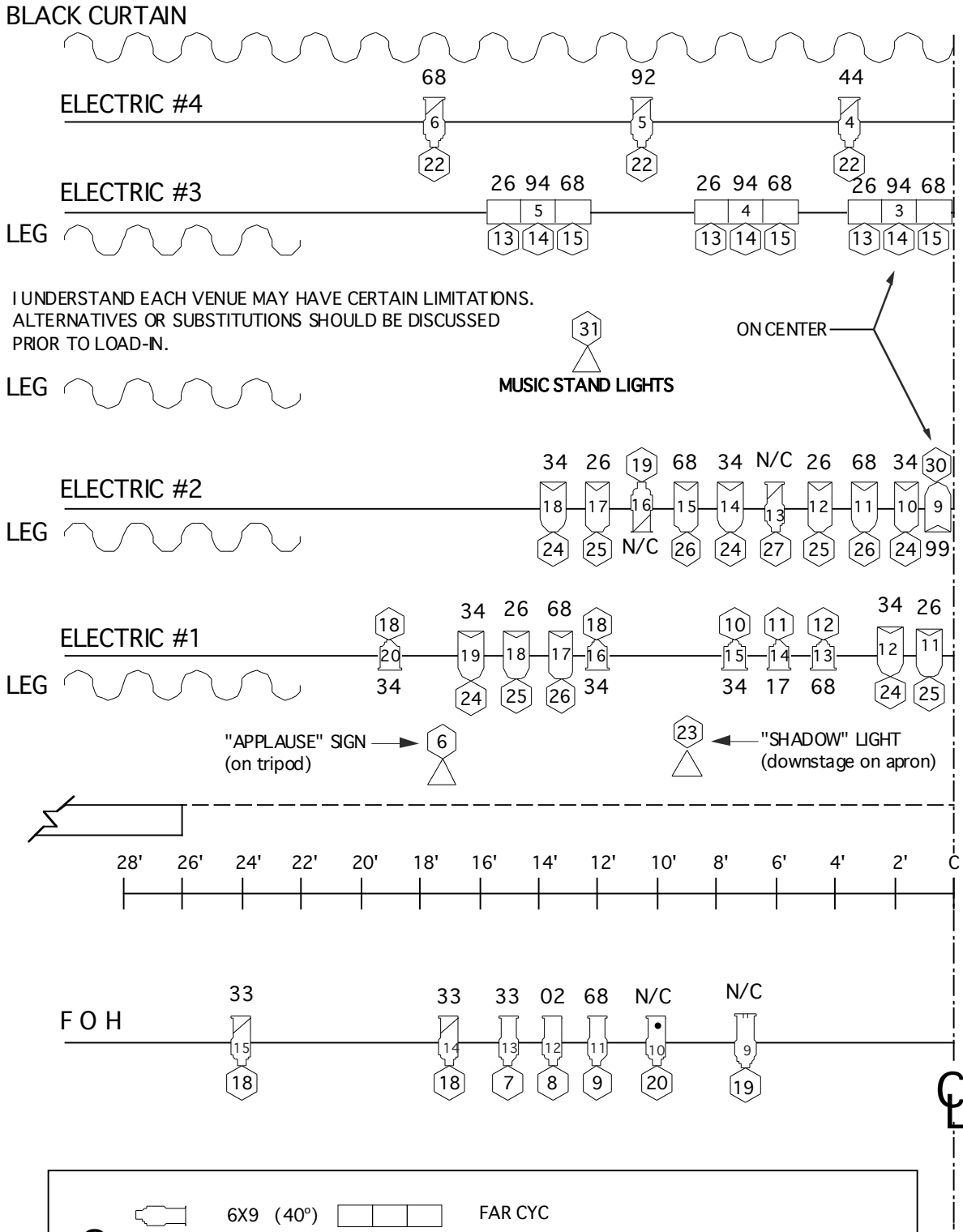

LEGEND		6X9 (40°)		FAR CYC
		6X12 (30°)		PAR WIDE
		6X22 (12°)		PAR NARROW
		8" FRESNEL		PRACTICAL

INST. NUMBER
GOBO
COLOR
CHANNEL
N/C
IRIS

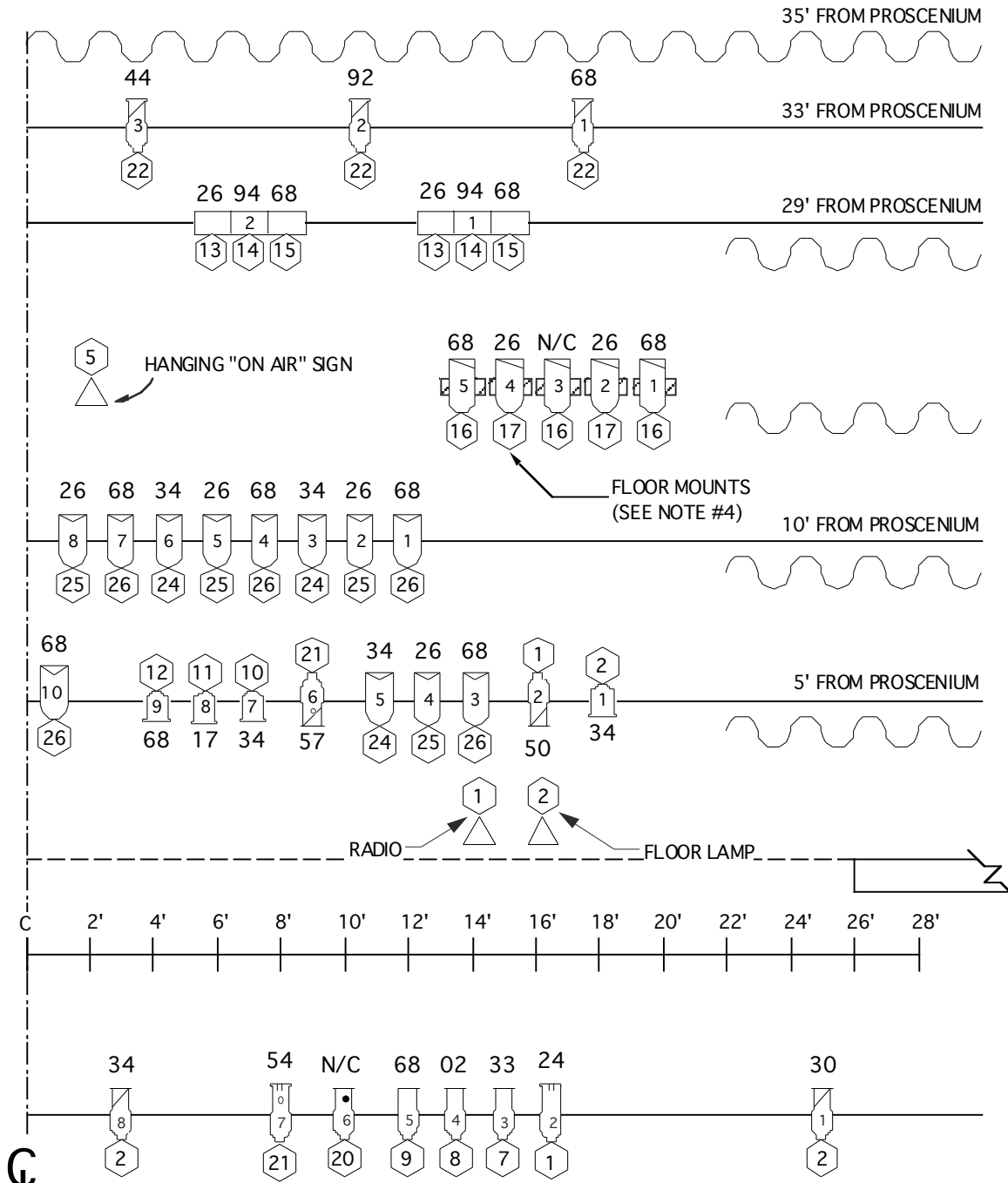

NOTES:

- 1-PLOT MUST BE HUNG AND GELLED PRIOR TO LOAD-IN.
- 2-FRONT OF HOUSE UNITS ARE BASED ON A MEDIUM THROW DISTANCE. IF YOUR FOH POSITION IS CLOSER OR FARTHER AWAY, PLEASE SUBSTITUTE APPROPRIATELY.
- 3-ALL PRACTICALS ARE SCENERY ELEMENTS THAT WE PROVIDE.
- 4-FLOOR MOUNTED PARS LIVE ON CENTER ABOUT ONE FOOT DOWN STAGE OF THE BLACK OUT.
- 5-CHAN 20 IS A GOBO EFFECT FOCUSED ON THE FLOOR. TWO ROSCO PATTERN #79117-"DENSE LEAVES 3" ARE NEEDED.
- 6-LEGS SHOULD BE TIED TO 22 FEET OFF CENTER.
- 7-ELECTRIC #4 SHOULD BE ABOUT 2 FEET DOWN STAGE OF THE BLACK OUT.
- 8-ELECTRICS #3 AND #4 CAN BE COMBINED IF THE ELLIPSOIDALS ARE EVENLY SPACED.
- 9-ALL GEL IS ROSCO LUX. SPOT COLOR IS ROSCO 02, 33, 54, 60, 132 (IN FRAMES 1 THRU 5 RESPECTIVELY).
- 10-BAND STAND LIGHTS WILL BE ON A DIMMER PATCHED INTO LIGHT BOARD AS CHANNEL 31.

**** FOR THE COMPLETE RADIO DAYS 8 PIECE RIDER, PLEASE GO TO [HTTP://WWW.FIVEBYDESIGN.COM/RADIODAYS.HTML](http://www.fivebydesign.com/radiodays.html)**

RADIO DAYS (8-PIECE) SET-UP DIAGRAM

BLACK CURTAIN 35' - 40' FROM PROSCENIUM

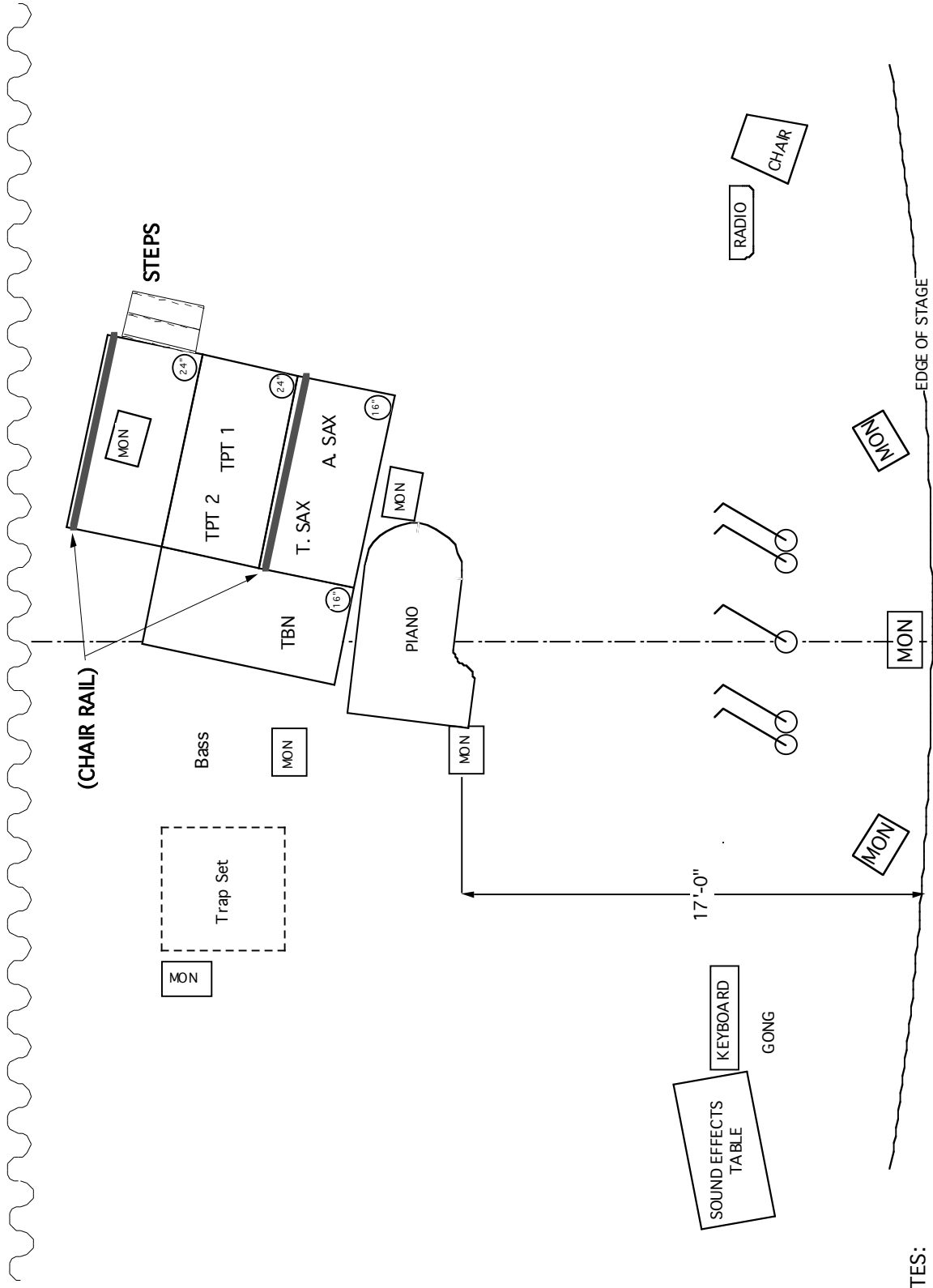

SET NOTES:

THE FOLLOWING SHOULD BE AVAILABLE AT LOAD-IN:

- *12, MUSIC STANDS WITH STAND LIGHTS (10 ONSTAGE, 2 OFFSTAGE RIGHT)
- *1, MUSIC STAND WITH NO LIGHT
- *1, 30" - 32" TAM TAM (GONG) WITH STAND (TO BE USED BY CAST MEMBER)
- *4, 4 FOOT BY 8 FOOT RISERS WITH SKIRTING -2 @ 16 INCHES - WITH CHAIR RAIL. HEIGHT MAY NEED TO BE ADJUSTED TO 8 INCHES. PLEASE HAVE OPTIONAL LEGS AVAILABLE. -2 @ 24 INCHES - WITH CHAIR RAIL.
- *1, 6 FOOT TABLE (FOR ONSTAGE)
- *1, 8 FOOT TABLE (FOR BACKSTAGE)
- *14, CHAIRS (8 OFFSTAGE RIGHT, 6 ONSTAGE)

**** FOR THE COMPLETE RADIO DAYS 8-PIECE RDER, GO TO [HTTP://WWW.FIVEBYDESIGN.COM/RADIODAYS.HTML](http://www.fivebydesign.com/radiodays.html)**

RADIO "HOLLY"-DAYS (8-PIECE) SOUND PLOT AND PATCH SHEET

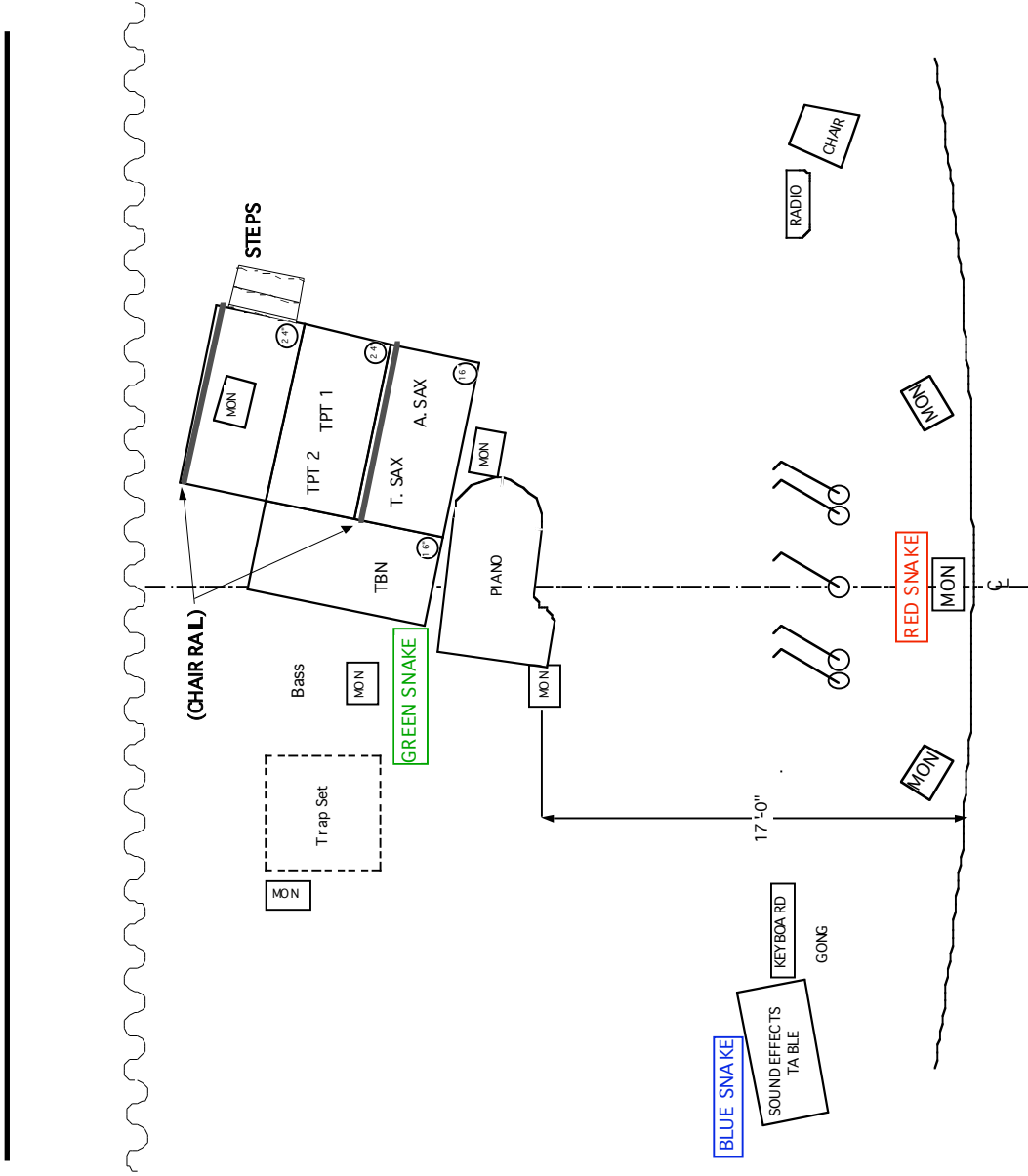

- NOTES:**
- 1: THE FRONT FIVE MICS, STANDS, AND ALL THE WIRELESS ARE PROVIDED BY ARTISTS
 - 2: VENUE MAY NEED TO PROVIDE 1-2 MONITORS TO BE USED AS NEEDED.

Mic	Sub Snake	Main Snake
Vocal 1	Red Snake 1	1
Vocal 2	Red Snake 2	2
Vocal 3	Red Snake 3	3
Vocal 4	Red Snake 4	4
Vocal 5	Red Snake 5	5
Piano Lo	Green Snake 1	10
Piano High	Green Snake 2	11
Drums	Green Snake 3	20
Bass	Green Snake 4	14
Sax 1	Green Snake 5	13
Sax 2	Green Snake 6	15
Flute	Green Snake 7	16
Trumpet 1	Green Snake 10	17
Trumpet 2	Green Snake 11	18
Bones	Green Snake 12	19
Thunder	Blue Snake 1	21
Floor	Blue Snake 2	22
Wind	Blue Snake 3	23
Door	Blue Snake 4	24
[open]	Blue Snake 5	-X-
Keyboard	Blue Snake 6	12
OffStage Announce	Blue Snake 7	7
Al's Wireless		6
Bell Boy Wireless		8
Monitors	-Send Lines-	
Delta Max (House)		A
Side Fill Fronts		B
Front Center		C
Piano/Bass		D
Horns		E
Side Fill (Traps)		F
Drums		26